

AOSIF Cummins Series

Product introduction

AOSiF
POWER GENERATOR



Model AC42 Generator set

37.5KVA/30KW



XIAMEN AOSIF ENGINEERING LTD.

General Performance Data

Prime Power	37.5KVA/30KW	Engine	Brand	Cummins
Stand by Power	42KVA/33KW		Model	4B3.9-G12
Frequency/Speed	60Hz/1800rpm	Control module	Deepsea 6120	
Rated Power Factor(cosφ)	0.8	Rated Current	45A	
Standard Voltage	277V/480V	Capacity of Breaker	63A	
Phases	3	Starting Voltage	DC24V	

Fuel consumption

Rated output	Fuel consumption rate	
	100%Standby	232g/KW.h
100%Prime	235g/KW.h	9.4L/h
75%Prime	251g/KW.h	7.5L/h
50%Prime	274g/KW.h	5.5L/h
25%Prime	396g/KW.h	4.0L/h

Standards followed

ISO9001	ISO14001
ISO8528	ISO12100
ISO13849	EN12601
GB12786	GB/T2820
IEC60034	IEC60204
CE	RETIE

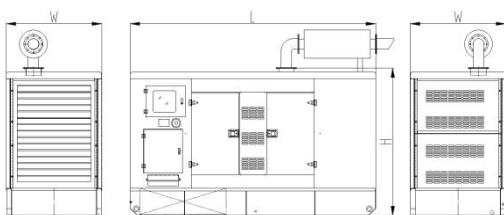
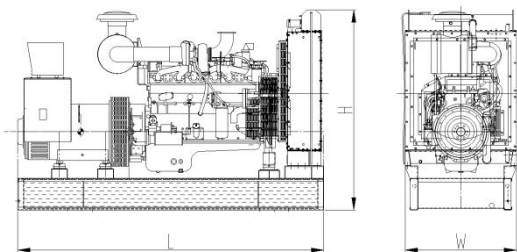

Dimensions and Weights

Type	Open	Silent
Length(mm)	1860	2250
Width(mm)	750	1000
Height(mm)	1350	1540
Weight(kg)	700	1100
Base fuel tank volume (L)	80	80

Engine specification

Basic parameter

Manufacturer	dongfeng Cummins
Model	4B3.9-G12
No. of cylinder	4
Type	4 cycle, Vertical In-line
Prime Power	33kw /44HP
Standby Power	36kw /48HP
Induction system	Natural air intake
Governor	Electronic speed
Bore x Stroke	102x120mm
Displacement	3.9L
Compression ratio	18.0:1
Oil Capacity(Total)	10.9L
Coolant Capacity(Engine only)	7.2L
Cranking Motor Voltage	DC24V

Fuel System

Type Injection system	BYC Type A inline pump
Min. Allowable flow of fuel to fuel pump	10.1 L/h

Lubrication system

Oil Pressure	
---Idle speed	207kPa
---Rated speed	345kPa
Max. allowable oil temperature	121°C
Offset sump oil capacity: low/high	9.5 /8.5L
Total system capacity	10.9L

Air induction system

Maximum allowable intake air restriction	
---with clean filter element	3.7kPa
---with dirty filter element	6.2kPa
Intake Air alarm temperature	82°C

Exhaust system

Max. allowable back pressure	10kPa
Standard exhaust pipe diameter	75mm

Cooling system

Coolant capacity	
---Engine only	7.2L
---Total system	15.2 L
---With heat exchanger	8L
Standard thermostat(modulating) range	82-95 °C
Minimum cap pressure	69kPa
Max. allowable top tank temperature for stand by/prime power	104/100 °C

Electric system

Min. recommended battery capacity (24V)	
---10°C(50°F) & above- 0°F CCA	312
--- 0°C(32°F) to 10°C(50°F)- 0°F CCA	312
---18°C(0°F) to 0°C(32°F)- 0°F CCA	312
Max. allowable resistance of Starting circuit	0.002ohm
Starter(heave,Anode)	DC24V
Battery recharge system, negative ground	40ampere

Alternator specification

Phases	3
Poles	4
Power factor(cosφ)	0.8
Winding connection	Star
Winding pitch	2/3
Voltage regulator type	AVR

Coating	Vacuum impregnation
Insulation class	H
Protection	IP23
Excitation system	Self-excited
Bearing	Single Bearing
Coupling	Flexible disc

Control system Introduction

Deepsea 6120 Auto start & auto mains failure control panel

Deepsea 6120 is an auto mains failure controller for single generator, it can monitor and protect the generator working all the time. it has a LCD display which clearly shows the status of the engine. this controller include seven inputs and six outputs. This controller can also be programmed using the front panel or by using DSE configuration Suite PC software

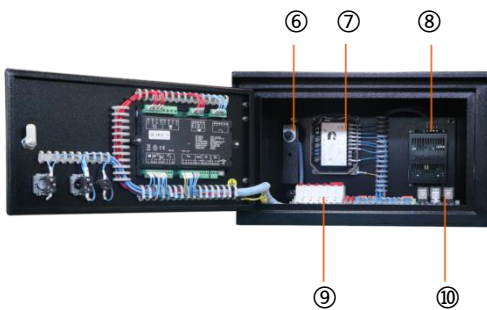
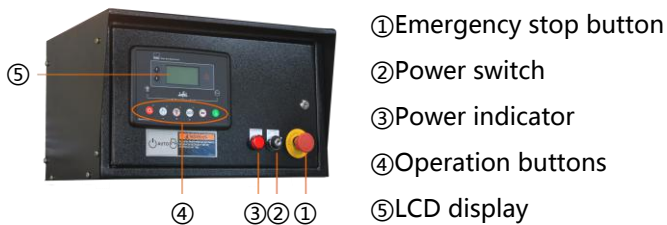

- ⑥ Voltage and frequency trimmer
- ⑦ Governor
- ⑧ Charger
- ⑨ MCB
- ⑩ Relay

Key Features:

- Auto start/stop, load transfer and alarming of generator
- Remote start on or off load
- With hierarchical loading function
- Multiple start/stop cycles can be preset
- 3 phase generator and mains voltage monitoring.
- Generator/load power detection(kW, kVA, kVA_r PF)
- Overload protection (kW)
- Load current monitoring and protection
- Engine speed protection
- Engine pre-heat
- Engine start idle & stop idle
- Battery voltage monitoring
- Start under the low battery
- 4 active outputs
- 4 digital inputs and 3 analogue inputs.
- 6 Custom digital input
- 6 outputs(4 configurable on magnetic pick-up, 6 configurable on Canbus version)
- DSE2130,DSE2157,DSE2548 expansion module can be connected
- Support 0-10V or 4-20mA oil pressure sensor

Main features:

- Multi language display
- Mains failure self starting
- The running time of the engine can be recorded to facilitate the maintenance and repair of the unit
- User-friendly set-up and button layout
- LCD display can display multiple parameters at the same time
- Support EFI engine
- IP65 rating (with optional gasket)
- PC and front panel configuration
- 100 event records
- Data recording and trend analysis

Protection:

- Two sets of protection parameters can be preset
- Normal alarm, electrical trip and shutdown alarm can be set to effectively monitor the engine speed,oil pressure, water temperature and oil level, as well as the frequency, voltage, current and power of the alternator, for complete engine/alternator protection
- Low Oil Pressure
- High water Temperature
- High voltage and low voltage
- Overspeed
- Emergency stop
- Fail to start

AOSIF Soundproof Canopy Introduction:

Standard Type :

- The arc angle structure makes the appearance beautiful and not easy to bump
- High quality coating powder, chemical surface treatment & 100-120um coating thickness greatly improving the anti-corrosion and anti rust level
- Stainless steel hinge & door lock are beautiful and anti-rust
- 2.0mm cold rolled plate used makes the body more solid
- The bottom forklift and loading port design enables easy loading and unloading
- The drainage outlets are all connected to the outside for easy operation
- The sufficient air in & out design ensure long-term and stable operation of the unit
- Isolation net is designed for air inlet, exhaust outlet and muffler outlet to prevent objects from entering the unit
- High density foam used inside effectively reduces noise
- Ceiling Lighting is equipped for easy operation
- The built-in base fuel tank with fuel filler set on the shell facilitates refueling
- Models above medium power range are designed with top hoisting mechanism to facilitate transportation of the unit.

Imitated container type :

- The shell is made of 3.0mm hot rolled steel plate so as to withstand the lifting capacity of 15-ton without deformation
- The switch cabinet and control panel are respectively set on both sides of the shell for easy maintenance & operation
- The shell looks similar to standard container, and can be loaded into 40HQ container for transportation, which is convenient for shipping
- The lifting eye holes are designed on the top same as the standard container for easy handling
- High density foam used inside effectively reduces noise
- The built-in base fuel tank with fuel filler set on the shell facilitates refueling
- Double emergency stop button set on different surfaces enables quick response to operation requirements
- The shell base is independent from the unit with 3mm thick checkered steel plate floor, which is beautiful & antiskid, and is convenient for overhaul & maintenance of the unit
- The door handle, lock and hinge are all made of stainless steel to avoid rusting
- The air out louver made of the mesh plate with powder coating and pasted with high-density glass fiber is beautiful and not easy to rust, and can further reduce the noise
- Isolation net is designed for air inlet, exhaust outlet and muffler outlet to prevent objects from entering the unit
- The sufficient air in & out design ensure long-term and stable operation of the unit
- The drainage outlets are all connected to the outside for easy operation
- Ceiling Lighting is equipped for easy operation

Standard container type :

- Can be shipped on board directly during transportation
- The mesh plate with powder coating and inner pasted with high-density glass fiber is installed inside the shell, which is beautiful and anti-rust, and can further reduce the noise
- 3mm thick checkered steel plate floor is beautiful & antiskid, and is convenient for overhaul & maintenance of the unit
- Double emergency stop button set on different surfaces enables quick response to operation requirements
- The independent daily fuel tank can be designed to put inside to meet requirements of continuous operation
- The fuel filler is set on the shell to facilitate refueling
- The switch cabinet and control panel are respectively set on both sides of the shell for easy maintenance & operation
- The air in & out louver made of the mesh plate with powder coating and pasted with high-density glass fiber is beautiful and not easy to rust, and can further reduce the noise
- Isolation net is designed for air inlet, exhaust outlet and muffler outlet to prevent objects from entering the unit
- The sufficient air in & out design ensure long-term and stable operation of the unit
- The drainage outlets are all connected to the outside for easy operation
- Ceiling Lighting is equipped for easy operation



Decomposition diagram introduction of AOSIF Typical Canopy



Standard supply scope:

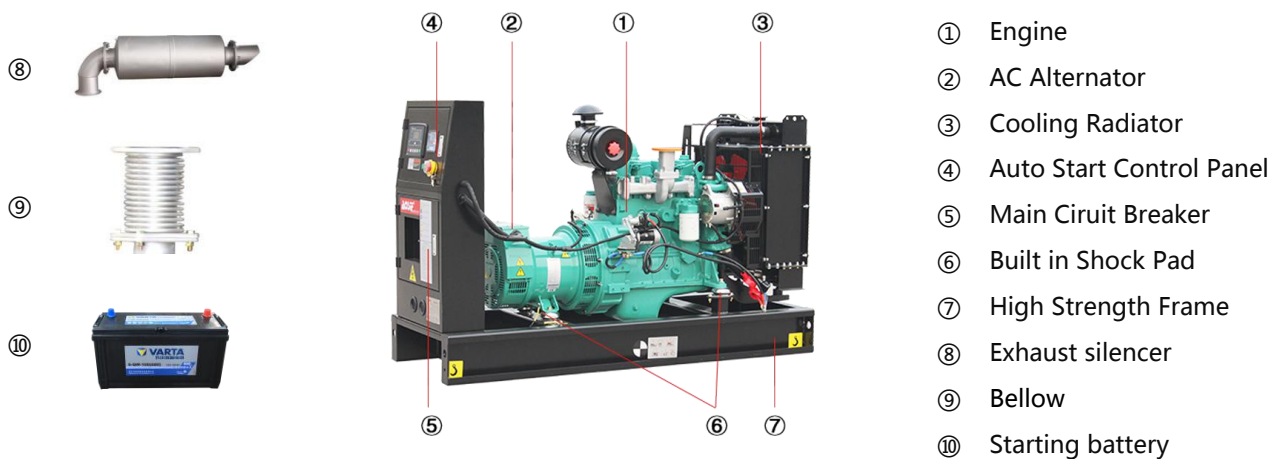

Optional supply scope:

Genset	Engine	Alternator	Control system
<ul style="list-style-type: none"> ● Tool box ● Base fuel tank ● External daily fuel tank ● Trailer 	<ul style="list-style-type: none"> ● Fuel heater ● Fuel and water separator 	<ul style="list-style-type: none"> ● Temp. detector for winding and bearing ● PMG ● Antirust, mildew and salt fog treatment ● Anti condensation heater 	<ul style="list-style-type: none"> ● ATS ● Synchronization System ● Adjustable earth relay
Breaker	Fuel system	Lub-oil system	Cooling system
<ul style="list-style-type: none"> ● ABB ● Schneider 	<ul style="list-style-type: none"> ● Low fuel level alarm ● Auto Fuel Pump ● T Valve 	<ul style="list-style-type: none"> ● Lub oil heater ● Temp.-sensor ● Oil drain Pump 	<ul style="list-style-type: none"> ● Elec.coolant Heater

Our Promises

- AOSIF Engineering provides a full line of brand new and high quality products.
- Each unit passes strictly loading test in factory before shipment.
- Quality Warranty is provided strictly in accordance with warranty terms.
- Three level service guarantee: Aosif dealers, Service outlets of engine/alternator manufacturers, Aosif service team.



XIAMEN AOSIF ENGINEERING LTD.

Marketing Center: Unit 1001, No.1 of Cheng Yi North Street, Software Park Phase III, Xiamen, China;

Factory: No.1088 Tangbian, Changtai Economic Development Zone, Zhangzhou, Fujian, China.

Website: www.aosif.com



You may get more information from our official account.

Specifications are subject to change without notice.