

# AOSIF VOLVO Series

Product introduction

**AOSiF**  
POWER GENERATOR



## Model AVV770 Generator set

# 700KVA/560KW

---



**XIAMEN AOSIF ENGINEERING LTD.**

## General Performance Data

Prime Power	700KVA/560KW	Engine	Brand	VOLVO
Stand by Power	770KVA/616KW		Model	TWD1645GE
Frequency/Speed	50Hz/1500rpm	Control module	Deepsea 6120	
Rated Power Factor(cosφ)	0.8	Rated Current	1010A	
Standard Voltage	230V/400V	Capacity of Breaker	1250A	
Phases	3	Starting Voltage	DC24V	

## Fuel consumption

Rated output	Fuel consumption rate
100%Standby	193 g/KW.h
100%Prime	191 g/KW.h
75%Prime	196 g/KW.h
50%Prime	206 g/KW.h
25%Prime	218 g/KW.h

## Standards followed

ISO9001	ISO14001
ISO8528	ISO12100
ISO13849	EN12601
GB12786	GB/T2820
IEC60034	IEC60204
CE	RETIE

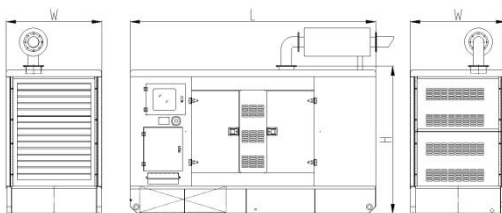

## Dimensions and Weights

Type	Open	Silent
Length(mm)	3430	4100
Width(mm)	1150	1500
Height(mm)	2180	2390
Weight(kg)	4589	5779
Base fuel tank volume (L)		

## Engine specification

### Basic parameter

Manufacturer	VOLVO
Model	TWD1645GE
Number of cylinders	6
Type	In-line four stroke
Prime Power	595kw /809HP
Standby Power	654kw /890HP
Total mass moment of inertia, J (mR <sup>2</sup> ) (SAE 1 14" flywheel)	4.40 kgm <sup>2</sup>
Governor type/make, standard	Volvo / EMS 2.3
Bore x Stroke	144x165mm
Displacement	16.12L
Compression ratio	16.8:1
Oil Capacity(Total)	48 L
Coolant Capacity(Engine only)	33 L
Cranking Motor Voltage	DC24V

### Fuel System

System return flow	25.0 litre/h
Injection pump type/make	Unit Injector Delphi E3

### Lubrication system

Lubricating oil consumption	
---Prime Power	0.10 litre/h
---Standby Power	0.11 litre/h
Oil system capacity including filters	48 L
Oil sump capacity:MAX/MIN	42L/32L
Oil pressure at rated speed	300 - 500 kPa

### Air induction system

Air consumption at:(+25°C and 100kPa)	
---Prime Power	41.2m <sup>3</sup> /min
---Standby Power	43.53m <sup>3</sup> /min

### Exhaust system

Heat rejection to exhaust at:(Prime Power)	415 kw
Exhaust gas temperature after turbine at:(Prime Power)	470°C

### Cooling system

Coolant capacity	
---Engine only	25 L
---Total coolant volume engine circuit	59.5 L
Coolant pump, HT(drive/ratio)	Belt / 1,85
Minimum coolant flow engine coolant circuit (at fully open thermostat)	6.5 l/s
Nominal coolant pressure before engine circuit coolant pump	50kPa
Maximum coolant temperature entering engine (25°C amb. Temp.)	82°C

### Electric system

Voltage and type (insulated from earth)	24V
Starter motor	
---make	Misubishi Electric
---type	24V 7 kW 12/3. 17F
---kW	7.0
Cranking current at +20°C	300A

## Alternator specification

Phases	3	Coating	Vacuum impregnation
Poles	4	Insulation class	H
Power factor(cosφ)	0.8	Protection	IP23
Winding connection	Star	Excitation system	Self-excited
Winding pitch	2/3	Bearing	Single Bearing
Voltage regulator type	AVR	Coupling	Flexible disc

## Control system Introduction

### Deepsea 6120 Auto start & auto mains failure control panel

**Deepsea 6120** is an auto mains failure controller for single generator, it can monitor and protect the generator working all the time. it has a LCD display which clearly shows the status of the engine. this controller include seven inputs and six outputs. This controller can also be programmed using the front panel or by using DSE configuration Suite PC software



- ⑥ Voltage and frequency trimmer
- ⑦ Governor
- ⑧ Charger
- ⑨ MCB
- ⑩ Relay

### Key Features:

- Auto start/stop, load transfer and alarming of generator
- Remote start on or off load
- With hierarchical loading function
- Multiple start/stop cycles can be preset
- 3 phase generator and mains voltage monitoring.
- Generator/load power detection(kW, kVA, kVA<sub>r</sub> PF)
- Overload protection (kW)
- Load current monitoring and protection
- Engine speed protection
- Engine pre-heat
- Engine start idle & stop idle
- Battery voltage monitoring
- Start under the low battery
- 4 active outputs
- 4 digital inputs and 3 analogue inputs.
- 6 Custom digital input
- 6 outputs(4 configurable on magnetic pick-up, 6 configurable on Canbus version)
- DSE2130,DSE2157,DSE2548 expansion module can be connected
- Support 0-10V or 4-20mA oil pressure sensor

### Main features:

- Multi language display
- Mains failure self starting
- The running time of the engine can be recorded to facilitate the maintenance and repair of the unit
- User-friendly set-up and button layout
- LCD display can display multiple parameters at the same time
- Support EFI engine
- IP65 rating (with optional gasket)
- PC and front panel configuration
- 100 event records
- Data recording and trend analysis

### Protection:

- Two sets of protection parameters can be preset
- Normal alarm, electrical trip and shutdown alarm can be set to effectively monitor the engine speed,oil pressure, water temperature and oil level, as well as the frequency, voltage, current and power of the alternator, for complete engine/alternator protection
- Low Oil Pressure
- High water Temperature
- High voltage and low voltage
- Overspeed
- Emergency stop
- Fail to start

## AOSIF Soundproof Canopy Introduction:

### Standard Type:

- The arc angle structure makes the appearance beautiful and not easy to bump
- High quality coating powder, chemical surface treatment & 100-120um coating thickness greatly improving the anti-corrosion and anti rust level
- Stainless steel hinge & door lock are beautiful and anti-rust
- 2.0mm cold rolled plate used makes the body more solid
- The bottom forklift and loading port design enables easy loading and unloading
- The drainage outlets are all connected to the outside for easy operation
- The sufficient air in & out design ensure long-term and stable operation of the unit
- Isolation net is designed for air inlet, exhaust outlet and muffler outlet to prevent objects from entering the unit
- High density foam used inside effectively reduces noise
- Ceiling Lighting is equipped for easy operation
- The built-in base fuel tank with fuel filler set on the shell facilitates refueling
- Models above medium power range are designed with top hoisting mechanism to facilitate transportation of the unit.

### Imitated container type:

- The shell is made of 3.0mm hot rolled steel plate so as to withstand the lifting capacity of 15-ton without deformation
- The switch cabinet and control panel are respectively set on both sides of the shell for easy maintenance & operation
- The shell looks similar to standard container, and can be loaded into 40HQ container for transportation, which is convenient for shipping
- The lifting eye holes are designed on the top same as the standard container for easy handling
- High density foam used inside effectively reduces noise
- The built-in base fuel tank with fuel filler set on the shell facilitates refueling
- Double emergency stop button set on different surfaces enables quick response to operation requirements
- The shell base is independent from the unit with 3mm thick checkered steel plate floor, which is beautiful & antiskid, and is convenient for overhaul & maintenance of the unit
- The door handle, lock and hinge are all made of stainless steel to avoid rusting
- The air out louver made of the mesh plate with powder coating and pasted with high-density glass fiber is beautiful and not easy to rust, and can further reduce the noise
- Isolation net is designed for air inlet, exhaust outlet and muffler outlet to prevent objects from entering the unit
- The sufficient air in & out design ensure long-term and stable operation of the unit
- The drainage outlets are all connected to the outside for easy operation
- Ceiling Lighting is equipped for easy operation

### Standard container type:

- Can be shipped on board directly during transportation
- The mesh plate with powder coating and inner pasted with high-density glass fiber is installed inside the shell, which is beautiful and anti-rust, and can further reduce the noise
- 3mm thick checkered steel plate floor is beautiful & antiskid, and is convenient for overhaul & maintenance of the unit
- Double emergency stop button set on different surfaces enables quick response to operation requirements
- The independent daily fuel tank can be designed to put inside to meet requirements of continuous operation
- The fuel filler is set on the shell to facilitate refueling
- The switch cabinet and control panel are respectively set on both sides of the shell for easy maintenance & operation
- The air in & out louver made of the mesh plate with powder coating and pasted with high-density glass fiber is beautiful and not easy to rust, and can further reduce the noise
- Isolation net is designed for air inlet, exhaust outlet and muffler outlet to prevent objects from entering the unit
- The sufficient air in & out design ensure long-term and stable operation of the unit
- The drainage outlets are all connected to the outside for easy operation
- Ceiling Lighting is equipped for easy operation



## Decomposition diagram introduction of AOSIF Typical Canopy



## Standard supply scope:

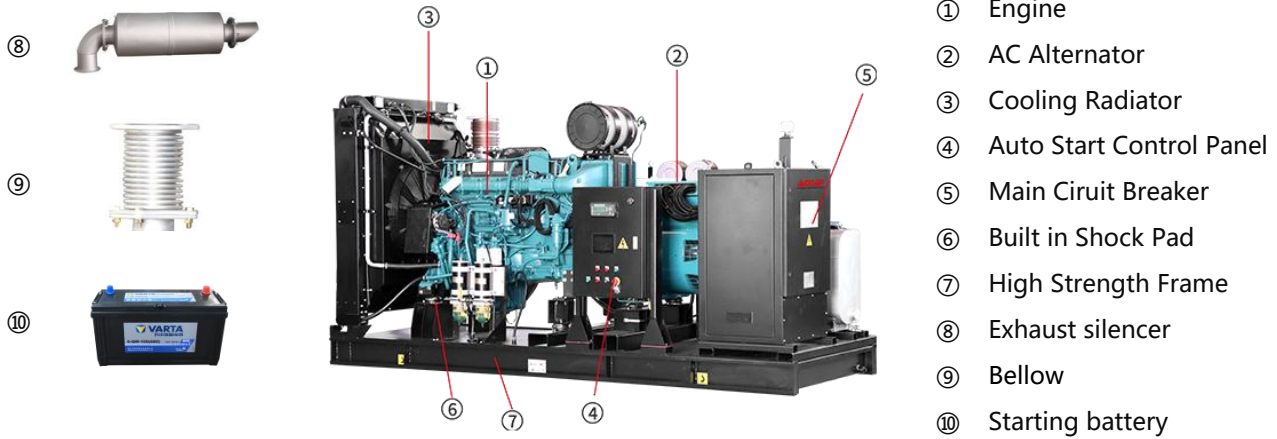

## Optional supply scope:

Genset	Engine	Alternator	Control system
<ul style="list-style-type: none"> <li>• Tool box</li> <li>• Base fuel tank</li> <li>• External daily fuel tank</li> <li>• Trailer</li> </ul>	<ul style="list-style-type: none"> <li>• Fuel heater</li> <li>• Fuel and water separator</li> </ul>	<ul style="list-style-type: none"> <li>• Temp. detector for winding and bearing</li> <li>• PMG</li> <li>• Antirust, mildew and salt fog treatment</li> <li>• Anti condensation heater</li> </ul>	<ul style="list-style-type: none"> <li>• ATS</li> <li>• Synchronization System</li> <li>• Adjustable earth relay</li> </ul>
Breaker	Fuel system	Lub-oil system	Cooling system
<ul style="list-style-type: none"> <li>• ABB</li> <li>• Schneider</li> </ul>	<ul style="list-style-type: none"> <li>• Low fuel level alarm</li> <li>• Auto Fuel Pump</li> <li>• T Valve</li> </ul>	<ul style="list-style-type: none"> <li>• Lub oil heater</li> <li>• Temp.-sensor</li> <li>• Oil drain Pump</li> </ul>	<ul style="list-style-type: none"> <li>• Elec.coolant Heater</li> </ul>

# Our Promises

- AOSIF Engineering provides a full line of brand new and high quality products.
- Each unit passes strictly loading test in factory before shipment.
- Quality Warranty is provided strictly in accordance with warranty terms.
- Three level service guarantee: Aosif dealers, Service outlets of engine/alternator manufacturers, Aosif service team.



XIAMEN AOSIF ENGINEERING LTD.

Marketing Center: Unit 1001, No.1 of Cheng Yi North Street, Software Park Phase III, Xiamen, China;

Factory: No.1088 Tangbian, Changtai Economic Development Zone, Zhangzhou, Fujian, China.

Website: [www.aosif.com](http://www.aosif.com)



**You may get more information from our official account.**

**Specifications are subject to change without notice.**